

# THE SQUARE RIGGER

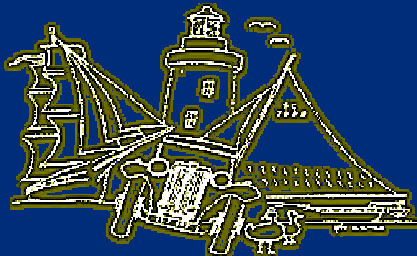

QUARTERLY NEWSLETTER OF  
THE CHESAPEAKE CHAPTER OF THE NEW ENGLAND MG-T REGISTER

[www.chesapeakechaptermgclub.com](http://www.chesapeakechaptermgclub.com)

FALL 2010

## Chairman's Comments

The most recent Chapter event, The Original British Car Day, took place for the 33rd consecutive year and in spite of the threat of bad weather still had a pretty good turnout. There's a summary on page 3 of how the Chapter fared overall. I want to thank all the members who volunteered their time to help set up the event as well as keep it going.

The next Chapter event is the Fall Ramble which is going to be a lot of fun. We have not done an excursion of this sort in some time and it should be a lot of fun. There's a summary of what to expect on page 3, along with the phone numbers for Milt Babirack and John Williams, so you can call them if you wish to attend. I know there has been a significant effort in planning this event and they will welcome any latecomers.

Speaking of significant efforts — I think you will all agree that the current issue of The Square Rigger is the best we have seen. Not only is there more information, but the quality gets better with each issue as well. Thank you Tom Carolan for a job well done.

Finally, let's hope for a break soon in this record breaking heat, so we can go out and enjoy our T's. It's hard to believe we went from 4 feet of snow in March to triple-digit temperatures in June.

Safety Fast!

Shaun English



## Chapter Officers

### Chairman

Shaun P. English  
9318 Brambly Lane  
Alexandria, VA 22309-3010  
703 229-3317  
[spenglish@aol.com](mailto:spenglish@aol.com)

### Vice Chairman

John Tokar  
4935 Tall Oaks Drive  
Monrovia, MD 21770  
(301) 865-1339  
[jtokar51@verizon.net](mailto:jtokar51@verizon.net)

### Secretary/Treasurer

Michelle Cattaneo  
772 Oak Grove Circle  
Severna Park, MD 21146  
(410) 647-6060  
[mcatta6799@aol.com](mailto:mcatta6799@aol.com)

### Membership Chairman

Milton Babirak  
47539 Coldspring Place  
Sterling, VA 20165-7446  
[mbabirak@babirakcarr.com](mailto:mbabirak@babirakcarr.com)  
(703) 406-4753

### Events Chairman

Lin Snider  
P.O. Box 145  
Walkersville, MD 21793  
(301) 845-2567  
[snidelf@aol.com](mailto:snidelf@aol.com)

### Regalia Chairman

Lin Snider (Acting)  
[see above]

### Technical Advisor

John Wright  
1640 River Road  
Upper Black Eddy, PA  
18972  
(610) 982-0140  
[mogfrog1@aol.com](mailto:mogfrog1@aol.com)

### Newsletter Editor

Tom Carolan  
1513 Red Oak Drive  
Silver Spring, MD 20910  
(301) 587-8177  
[tjcarolan@comcast.net](mailto:tjcarolan@comcast.net)  
[thomascarolan@me.com](mailto:thomascarolan@me.com)

### Historian

Tom Carolan  
[see above]

### Chairpersons Emeriti

Len and Ruth Renken-  
berger  
8245 Ingleton Circle  
Easton MD 21601  
(410) 822-6061  
[renk@atlanticbb.net](mailto:renk@atlanticbb.net)

## Editor's Corner

09/01/10

### Origins and Purpose

The Chesapeake Chapter of the New England MG-T Register was organized during the summer of 1971 by Register members in the Baltimore-Washington area where local interest in classic MGs was high. Its purpose was and still is to encourage the maintenance, preservation and enjoyment of T-Series and other vintage MGs. We welcome new members who share our interest in these unique cars. Membership in our parent organization, the New England MG-T Register, Ltd., and payment of modest annual dues are the only requirements. Membership application forms can be found on our Chapter's website: [www.chesapeakechaptermgclub.com](http://www.chesapeakechaptermgclub.com)

This Newsletter is circulated electronically on a quarterly basis to Members who possess email capability, and by regular mail to Members who do not. The electronic version contains color photos, whereas the regular-mail version is in black & white. In any event, the full color version is always available for subsequent viewing on and downloading from our website.

We're always on the lookout for stories, technical submissions, anecdotes, jokes, cartoons, photographs and other contributions of interest to MG fans. In addition, we seek to encourage fullest possible participation by Members in Chapter events, mention of which can be found in further pages of this Newsletter.

### Circulation Reminder

Please remember that in order for electronic circulation of this Newsletter to operate effectively, **IT IS IMPORTANT** that you notify us of any address changes, especially those pertaining to email. All of you seem to have taken this advice to heart, for which we thank you.

### Celebrating the TD

Since August 2008 we have featured a string of eight early MG road tests that first appeared in the UK many decades ago. They began with the 1929 MG "Midget" Two-Seater and worked up gradually over time to the 1945-49 MGTC (celebrated in this issue on pages 4-13). We are grateful to those who contributed TC and other material for this issue. We also thank Steve Sayer, Dan Leonard, John Wright, Steve Mefferd and Mike Hughes for their photo contributions.

Our Winter issue, to be circulated in December, will focus on the MGTD. To help us celebrate that fabled vehicle, we again invite you to send us your favorite stories and reminiscences, this time about TDs you own, have owned or sorely wish you had owned.

### T-Series Racing

As noted on page 7, our Chapter boasts members who are or have been active in racing T-Series MGs (along with other British marques), but we may not have a clear idea of who or how many those members are. We'd very much like to hear about their adventures on and around the track.

### MG Quiz Feature

With this issue we're starting a new feature entitled "Stump the Chapter." The first question can be found on page 10. Members who submit correct answer(s) to the Editor will be applauded in subsequent issues and can bask in the glow of our admiration. □

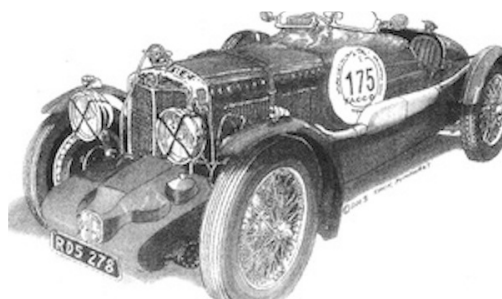

---

**Membership News**  
**Milton Babirak**  
**Membership Chairman**

**We welcome:**

**Charles & Erica Kropp**      **Malcolm & Marla Collum**  
**105 Race Street**              **1905 33rd Street, SE**  
**P.O. Box 277**                  **Washington, DC 20020**  
**Vienna, MD 21869-0277**      **Tel. (202) 584-4072**  
**Tel. (410) 376-0120**          **[malcomcollum@hotmail.com](mailto:malcomcollum@hotmail.com)**  
**[ckropp28@mc.com](mailto:ckropp28@mc.com)**

1949 MGTC

**Michael & Christine Cole**      **Ace & Lynne Sarich**  
**7621 Warbler Lane**              **1571 St. Margarets Road**  
**Derwood, MD 20855**              **Annapolis, MD 21409**  
**Tel. (301) 330-8467**              **Tel. (410) 757-5836**  
**[mcole01@comcast.net](mailto:mcole01@comcast.net)**          **[ace@sarich.com](mailto:ace@sarich.com)**

1954 MGTF

1951 MGTD

---

**Upcoming Chapter & Chapter-Related Events**

(For details, click on the blue links)

**Fall Ramble**

Our Chapter will conduct a Fall Ramble through the Blue Ridge Mountains on Friday, Saturday and Sunday, October 15, 16 and 17. Several Members have already signed up to participate. On the first day, the trip will start at the Old Mill in Aldie, VA, and motor through a very scenic route past Middleburg, Marshall, Flint Hill, and Washington to Sperryville. A Route Book is being prepared for participants. Most will lodge at the Hopkins Ordinary in Sperryville on Friday and Saturday nights.

There will be two day-trips to choose from on Saturday, the 16th. One will take participants over the Blue Ridge Mountains to Luray, stop for lunch there, and visit the Car Museum at Luray Caverns before returning to Sperryville.

The other day-trip will head south from Sperryville to Syria, visit the Graves Mountain Resort for the annual Apple Festival, which includes many events and activities. Lunch can be purchased at the Festival. Dinner is planned for both groups at the Thornton Grill on Friday night and at the Blue Rock Inn on Saturday night in Sperryville.

Everyone will return to Aldie on Sunday. If you wish to take part in this enjoyable excursion, please contact Milton Babirak at (703) 501-7924 or John Williams at (703) 321-0504.

**NEMGTR GOF 88**

Our parent organization, the New England MG "T" Register, will hold this regional event at Mystic, CT from Wednesday to

Sunday, September 22- 26.

[www.nemgtr.org/index.php?option=com\\_content&view=article&id=55&Itemid=159](http://www.nemgtr.org/index.php?option=com_content&view=article&id=55&Itemid=159)

---

**Recent Chapter Events**

**The 33rd Original British Car Day**

The Weather Man wasn't kidding when he predicted rain, thunder and lightning would make their appearance around mid-day on June 6. Even so, we started the day with a respectable turnout: 140 cars pre-registered and around 100 more registered at the gate. Their numbers began to dwindle once the rains arrived, so we chose to make the best of things and to speed up the awards process. As in the past, live music served to enhance the proceedings.

The List of Awards Winners has been posted on our Chapter's web site. To consult it, click on:

[www.chesapeakechaptermgclub.com/OBCD/10BCD/OBDCWinners.pdf](http://www.chesapeakechaptermgclub.com/OBCD/10BCD/OBDCWinners.pdf)

To view photographs taken at the event, click on:

[www.chesapeakechaptermgclub.com/OBCD/10BCD/SquareRiggerSupplementOBCCDay2010.pdf](http://www.chesapeakechaptermgclub.com/OBCD/10BCD/SquareRiggerSupplementOBCCDay2010.pdf)

---

**The Original British Car Day 2010**  
**Financial Statement**

**INCOME SUMMARY**

<b>Pre-registration (120)</b>	<b>\$1,970.00</b>
<b>Drive-in Registration (110)</b>	<b>\$3,032.00</b>
<b>Vendors, Pre-registered (10)</b>	<b>\$365.00</b>
<b>Vendors, Drive-in (7)</b>	<b>\$245.00</b>
<b>Spectator Cars (370)</b>	<b>\$1,850.00</b>
<b>Stuffer Ads (2)</b>	<b>\$150.00</b>
<b>Program Ads (11)</b>	<b>\$1,625.00</b>
<b>Regalia Sales</b>	<b>\$374.00</b>
<b>Vendor Donation (1)</b>	<b>\$75.00</b>
	<b>Total: \$9,686.00</b>
<b>Cash Box Advance</b>	<b>(-) \$400.00</b>
	<b>\$9,286.00</b>

**EXPENSE SUMMARY**

<b>OBCD Supplies</b>	<b>\$93.33</b>
<b>Radio Rental</b>	<b>\$50.00</b>
<b>Road Sign</b>	<b>\$48.71</b>
<b>Trophies</b>	<b>\$2,247.41</b>
<b>Copy Services (ballots/instructs.)</b>	<b>\$127.84</b>
<b>Post Card Printing/Postage</b>	<b>\$1,233.60</b>
<b>Program Printing/Graphics</b>	<b>\$1,343.94</b>
<b>Tee Shirts/Graphics Design</b>	<b>\$339.70</b>
<b>Dash Plaques</b>	<b>\$732.95</b>
<b>Porta-John Rental</b>	<b>\$590.00</b>
<b>PA System Rental</b>	<b>TBD</b>
<b>Star Spangled Big Band</b>	<b>\$350.00</b>
	<b>Total: \$7,157.48</b>

<b>GROSS INCOME</b>	<b>\$2,128.52</b>
<b>DONATIONS</b>	
LHS Band Boosters	\$500.00
Lutheran Church Youth Group	\$200.00
<b>TOTAL DONATIONS</b>	<b>\$700.00</b>
<b>NET INCOME</b>	<b>Total: \$1,428.52</b>

---



---



---

## Upcoming Events Sponsored by Others

### Virginia Scottish Games

Held at the Great Meadow, The Plains, VA, on the weekend of September 4-5. [www.vascottishgames.org/](http://www.vascottishgames.org/)

### British Car Club of Delaware 2010 Show

To be held at Delaware City, DE, on Saturday, September 18. [www.bccdelaware.com/Car%20Show%20Flyer%202010.pdf](http://www.bccdelaware.com/Car%20Show%20Flyer%202010.pdf)

### Classics on the James Green

This show, sponsored by the Central Virginia British Car Club, is scheduled for the weekend of September 18-19 at the New Kent Winery, New Kent City, VA.

<http://cvbcc.com/britishcarclub.php>

### Hagley Museum Car Show

On Sunday, September 19, an impressive display, selected by invitation only, of more than 600 antique and restored cars dating from the early 1900s to the 1980s. Venue: the Museum grounds near Wilmington, DE.

[www.hagley.lib.de.us/events.html](http://www.hagley.lib.de.us/events.html)

### MGs on The Rocks

Mounted by MGs of Baltimore at its usual venue, The Rocks State Park near Jarrettsville, MD, on Saturday, September 25. [www.mgsofbaltimore.com](http://www.mgsofbaltimore.com)

### Fall Carlisle Collector Car Exhibition and Swap Meet

To be held at Carlisle, PA, for 5 days, beginning on Wednesday, Sept. 29. [www.carlisleevents.com/ce/events/fall-carlisle/](http://www.carlisleevents.com/ce/events/fall-carlisle/)

### SVBCC Fall Festival

The 25th annual version of this event, hosted by the Shenandoah Valley British Car Club, will take place at Waynesboro, VA on Wednesday through Friday, October 1 to 3. [www.svbcc.net](http://www.svbcc.net)

### ACA Eastern Fall Meet

This regional show mounted annually by the Antique Automobile Club of America at Hershey, PA will run from Wednesday, October 6 through Saturday, October 9.

[www.aaca.org/Calendar](http://www.aaca.org/Calendar)

### Brits by the Bay

The 1010 Autumn Fall Classic, hosted by Triumphs Around the Chesapeake (TRAC), will take place at the Carroll County Farm Museum, Westminster, MD on Saturday, October 9, starting at 9:30 am. [www.tracltd.org](http://www.tracltd.org)

### Hunt Country Classic

Willoughby Farm near Middleburg, VA, remains the traditional venue for this show, put on by the MG Car Club (DC Centre) on Sunday, October 10. [www.mgcarclubdc.com](http://www.mgcarclubdc.com)

### Rockville Antique and Classic Car Show

Will take place from 11:30 am to 3:30 pm on Saturday, October 16 at the Glenview Mansion, Rockville, MD Civic Center Park. [www.rockvillemd.gov/events/carshow.htm](http://www.rockvillemd.gov/events/carshow.htm) □

---



---



---

# Celebrating the TC

## TC Memories

By Bob Little

I remember the first TC I ever saw. It must have been in the late 1950s or very early 1960s. I was at a boatyard in New London, Connecticut working on an old wooden sloop I was trying to rescue from a future of rot and decay.

Behind the yard, back by the road, there were a series of open stalls or sheds. Among the boat gear and equipment stored in them, I spied what looked like an amazing vehicle. The first things I noticed were a great-looking wire wheel peeking out from under a very rectangular and dirty black body. It was the biggest wire wheel I had ever seen, mounted with a skinny, motorcycle-style tire.

I needed to inspect this mysterious vehicle more closely. It

seemed to have been stuffed into a space that was too small for it. Clothes were piled on the leather seats, and some sort of bag sat on the wooden floorboards, while an amazingly functional-looking dashboard, a wonderfully long hood, and those sweeping front fenders all came into view as I poked further into the mess of stuff in the shed.

It looked like a car from another era, very unlike the Thunderbirds, Corvettes, bulbous old Plymouths, woody station wagons, etc. that I had seen on Connecticut roads in the late 1950s.

I had read books about earlier days when Duesenbergs, boat-tail speedsters, Auburns and such had graced the driveways of old shingled cottages along the Connecticut and Rhode Island shore-

lines. This was a car that came right out of the pages of the best fiction I had been reading. Dirty, dusty, looking abandoned and neglected, I just knew there was a possibility it had been cast aside, offering me an opportunity to step in on a rescue mission. Instant fascination and excitement were already coursing through my veins as I headed toward the small shed that housed the marina's office.

Once there, I inquired what that car was doing out back in the shed. Did anyone know the owner?"

"Oh, yes — that car belongs to a fellow named Dan Blagdon. He lives over in Essex, was headed out on a sailing cruise to Newport, but fell and broke his arm. He can't drive with a cast on, but he plans to collect it once his cast is removed. It's a 1948 MGTC. Great car, don't you think?" came from the boatyard's manager, who seemed to know something about everything and everybody in the vicinity.

I had been bitten by the TC bug! I kept an eye on that car for the next couple of weeks, as I sanded and varnished the wood on the old sloop. The MG sat there every day looking ever more appealing — rich with an air of mystery and intrigue. What a great car! I thought. I imagined the sound of the engine coming out of that long exhaust while motoring along leafy back country roads, wind in our faces, a pretty girl next to me with her hair blowing in the breeze, the sound of upshifts and downshifts, tires side-slipping on the country tar-and-gravel roads along the shorelines. Wow! I was already hooked on that car, and I had never seen it in motion.

Then one day, it moved! No warning, no notice, it was simply gone. I stared at the hole where it had sat and dreamed it might reappear — but it was gone, and gone for good. And for me, that boatyard would seem forever empty.

I can still see that empty spot in the shed in my mind today. A spot once filled with excitement, swooping fenders, spindly wire wheels, black leather worn seats, smells of oil and gasoline, and lots of dusty black paint on a long engine bonnet. I didn't catch My Dream that day, but a journey began — a quest, actually — the moment I discovered that little TC had gone away. A quest to fill the newly-emptied spots in my soul and in my heart, a lust for the wonder and amazement that little black TC had brought to my world, for those few weeks when it was the only thing that occupied my thoughts all day long and every night. □

---



---

### **Me and TC 9815**

By Steve Sayer

Hello, fellow enthusiasts. My name is Steve Sayer, and I'm the proud owner of TC 9815. I joined the Chesapeake Chapter in 1985, shortly after purchasing a yellow TF 1500. Now where have those 25 years gone? From a very early age I've been a British car fanatic, having driven a TR 4 and a TR 250 through high school and college. At age 26 due to deteriorating vision I had to give up driving. I needed something to keep me busy so I brought the TF into my life. It became an instant

addiction, and in less than two years I found myself searching for a TC project car.

After several and long discouraging road trips to examine some pitiful specimens, I stumbled onto TC 9815 less than five miles from my home. She arrived in my driveway via flatbed in August of 1987. She barely ran and had no brakes, but she was complete. That's when the fun began. I had the body off two days later. I stashed her wings all over the neighborhood. I was amazed at how much room one of these little cars can take up once they are taken apart in a one-car garage. I sealed the body in plastic and concentrated on the chassis and drivetrain first. The addiction quickly set in. My brother-in-law and several friends from the dealership I worked at jumped in to help. As long as I kept my refrigerator stocked, I had people who wanted to scrape, sand, paint or do whatever else was needed at the time.

In January of 1988 the completed beautiful black rolling chassis came out and the tub came in. Set up on sawhorses with a 2X4 jig, I discovered it was in far worse shape than I expected. I basically replaced every piece of wood supplied by Abingdon Spares, along with new metal front quarter sections.



The next eight months or so were spent building a body. We were clueless, but committed. Among other obstacles, we had to work around improperly made hinge-pillars. In the end we had a nice solid tub with some of the most "solid" closing doors I've ever heard on a TC. We used lacquer paint with an old Binx siphon gun and with no experience came out with a finish whose reflection you could comb your hair in. In the meantime, the engine had been disassembled and the block, crank and head machined. I found that the Black and Decker Workmate makes a wonderful engine stand for the XPAG. Once the engine and tub were done, they joined the chassis in one evening. It almost looked like a car now. More people wanted to get involved. My Mother worked on the upholstery and put the finish on the wooden dash. Progress went from back to front. First the gas tank, then the rear wings. At this point she was running as well and could be driven up and down the driveway. The interior was slowly coming together at the same time. Next, the front wings and running boards. Finally came the bonnet, the crowning glory. She was a car again. She was my TC, and she was beautiful.

I chose the green-on-green combination because I'd seen it less than any other combo. I came very close to Old English White-with green but finally stuck with my original decision. On Memorial Day 1989, TC 9815 hit the streets for the first time in her new life. Her first stop was at the home of her previous owner, who was speechless. The second stop was at Bill Porter's house. A longtime Chapter member, Bill had kindly let me use "Roots,"

his beloved prize-winning 1946 TC, as a reference guide throughout this journey. Two weeks later I threw a party for everyone involved in the restoration, with TC 9815 out in front of the house with green balloons hanging from her corners.



TC 9815 has been finished for 21 years now. She's only missed one OBCDay in all that time, the one on which it rained from start to finish. I just couldn't subject her to that. During these 21 years I let the TF go and picked up a Morgan. By now, I've pretty much lost my vision completely, yet I still do all repairs and maintenance on both cars. Since 1989, I've had the engine out and apart once and the transmission twice. The only work ever outsourced has been the engine and steering-box machine work, plus the mounting of new tires last year. I was able to dismount the old tires, but I couldn't get the new ones on to save my life.

So, after 21 years my TC still looks great from ten feet away. There are lots of little chips and cracks in the brittle lacquer, but she's still a TC, and she's mine, and that's what makes her so wonderful. She drives beautifully and is a true pleasure to ride in. The smiles and waves she evokes when out on the road are the best. The only problem with these 21 TC years is that they've gone by too fast.

I'd love to hear some TC stories from other past and present owners. ☐

---



---

### TC Adventures from Behind

By John Wright

I was asked by our esteemed Editor to write a little piece about a memory about TCs. In the early days of Linda's and my entry in-to the world of the Chesapeake Chapter, we had a BRG TD with a bonnet strap. We drove that all over with our very young son Johnny in the back. That's right, we did that . . . couldn't today that's for sure. Wouldn't today, either. Back about 1973 or so a bunch of us decided it would be a good thing to do to go up to Watkins Glen for the GOF. Linda and I and Johnny had never driven anything close to that distance before in a T. We packed up the TD (it had a Laystall head, which is another story) and head-ed north. We have by now a small caravan going and we pick up the Renkenbergers along the way. We were an adventurous bunch with the TDs and TFs following the Renkenberger's yellow TC with

the bicycle whip with the Sorry Safari flag on top. Made them easy to see and follow as we made our way up Route 70 somewhere north of Gaithersburg.

As I recall, Linda and I are right behind the yellow TC mesmerized by the square-rigger look of the car. All of a sudden the TC's tonneau starts a-flappin' in the wind. Ruth, the consummate navigator, calmly reaches around with her left arm and grabs the tonneau and snaps it back into place. A minute later this happens again, then again and finally it comes un-snapped with the exception of one snap near Renk's right shoulder.

We're in the right hand lane pushing our T's pretty hard to keep up with traffic that morning. We're on the lookout for errant Buicks and Detroit tanks when Ruth turns completely around in her seat, on her knees, and reaches all the way back to the spare wheel to grab hold of the flapping end of the tonneau. You really had to be there and some of you will no doubt remember this story. But there is Ruth in her apple knit hat tending to the tonneau; meanwhile those Buick and Detroit tanks are peeling off to the shoulders on both sides, giving the Renks plenty of room; after all, the driver is making repairs to the rear of the car at 60 mph on Route 70 for gosh sakes, right? Ruth gets it all back in order and the big cars quietly return to their lanes. Each passes us and the Renkenbergers with slight stares of disbelief as they scoot on past and out of danger. I don't think we stopped until we got somewhere in Pennsylvania. We had a lot of laughs during that break. ☐

---



---

### Off to the Races

Our colleague Dan Leonard has drawn our attention to a noteworthy article about his 1949 TC No. 409 "Special" currently featured in the internet technical forum, *British Race Car* (BRC).

Originally modified for racing back in the 1950s, the car was acquired by Dan in 2008 and then given a more extensive racing preparation. She weighs in today at 1,500 lbs., compared to the stock TC's weight of c.1,630 lbs. The article's description of the car's previous racing history, along with technical aspects of its up-to-date modifications, makes interesting reading — the more so because it is accompanied by 40 photographs recording the work in painstaking detail. Members can view it at:

[www.britishracecar.com/DanLeonard-MG-TC.htm](http://www.britishracecar.com/DanLeonard-MG-TC.htm)

The following photos were taken recently at the Summit Point Raceway in West Virginia. That's Dan in the cockpit.





So, we now know there's a TC in our midst that qualifies as a true state-of-the-art race car. Our Membership Directory shows that several other MG racers are stabled by Chapter members (Bob Schoepfle and Hank Giffin, to be precise). To the best of our knowledge, however, Dan's is the only one based on a TC. □

---



---

## T-Tech

By John Wright  
Technical Advisor

### TC Front Stub Axles

This article begins with a short update on the brake overhaul I discussed in the December 2009 issue. My TC brakes have begun to bed in nicely. At first I must say that with new shoes and ALFIN drums I expected more, much more. But now, after several miles the new parts are working fine and the car has better brakes than ever before during my stewardship. I hope it lasts, and I'll be pulling the rear drums off soon to double check. I don't think the ALFINs provide a greater degree of stopping power with normal use over the original pressed steel drums, but under heavy breaking and spirited driving I think they will come into their own very quickly and make a positive impression with their added cooling capacity. And Man! They sure look nice with their purposeful looking rib design.

The other topic I want to discuss is the front spindle or stub axle replacement. This can be a rather big deal and all TC owners should be aware of the potential for danger of this original part. Face it, your old TC, or TA or TB for that matter, is 60-some years old, and you don't know what it's been through in its previous life before it started living the good life with you. Having the spindles magnafluxed periodically and tended to if necessary, or even going so far as to have them updated as I have done, is a good safe idea.

Check with our Canadian friend Bob Grunau ([grunau.garage@sympatico.ca](mailto:grunau.garage@sympatico.ca)) to see if he will take your old steering knuckle stub axle, accurately cut off and bore out the old axle, and insert a new machined axle through the kingpin side. This new axle will be similar to the increased size of those on the TD/TF/MGA and will require new axle nuts. (See page #103 in *TCs Forever* for an excellent drawing). This is an opportune time to fit kingpins and bushings as well. The temperatures required to heat the spindle to 650° F in order to accept the frozen axle (-385° F) are quite extreme and would be detrimental to the bushings. Bob Grunau performed this work to the stub axles of TC 5030 and although I always felt its steering was quite good (for a TC) it's even better now and safer as well, which can be attributed to the new bushings and stub axles.



There's quite a bit written about TCs and their steering parts on the internet and in great books like the aforementioned *TCs Forever*. Check out [mg-tabc.org/techn-up.tcs spindles.htm](http://mg-tabc.org/techn-up.tcs spindles.htm) for an excellent article written by Peter Pleitner. Peter built a fixture to facilitate the repair of his spindles. It's quite a read and not a job for the faint of heart, and none of this is for the inexperienced. Makes Bob G.'s machine work a bargain. Before you tackle this sort of job, make sure you search as I did to find out all about the services and parts available. TCs, and all old cars really, have a few problems like this that need attention. It's good to know what they are and that folks out there are continuing to develop repair techniques to keep them safely on the road. □

January 1947

**The M.G. "TC" Midget 2-Seater****(This photograph did not accompany the original article)**

***A very well-appointed car with a lively performance. Excellent roadholding and braking, and effective weather protection.***

It is good to know that the ever-popular M.G. Midget has survived the war and is in production again. It is the same trim, efficient 2-seater we knew from pre-strife times, with a 1,250-c.c., pushrod o.h.v. 4 cylinder engine, 4-speed gear box, ½ elliptic suspension, now improved in a number of practical ways and endowed with greater elbow room and even better weather protection.

We took one of these cars over from the M.G. works at Abingdon last November and subjected it to a strenuous 400 miles test; the more we drove it, the more reluctant did we become to take it back to Mr. Cox, M.G.'s Publicity Manager. From the commencement a driver feels at home in this M.G. and, as he enthuses over the comfortable driving position and the layout of the controls, his passenger is invariably praising the comfortable seating and the very generous leg room. The bench-type front seat has been contrived so that not only is it possible to slide the two separate cushions forward, but also to adjust the rake of the squab, while the steering column is telescopic, so that the best seating position is quickly attainable. The seat strikes just the right balance between sponginess and hardness, and, while perfectly comfortable, the driver is prevented from rolling about when indulging in faster-than-normal cornering. For competition work raising the cushion some 3 in. would aid visibility, as the bonnet slopes upward to some extent, although both wings are visible in any case. M.G.'s have always fitted the near-perfect handbrake and the centrally-disposed lever on the "T.C." is no exception. Of "fly-off" type, it really holds the car, releases instantaneously when

pulled back, and locks effectively if the thumb-catch is pressed down, it is indeed an excellent brake.

The central, remote-gear-lever calls for equal praise. It could hardly be better placed, is short, absolutely rigid, with a pleasantly slim grip. This is well merited, for the synchromesh gear-box is one of the nicest we have operated. The synchromesh works well, but double de-clutching is equally effective, and upward and downward changes are really quick. The change back into top gear from 3rd is very pleasant, helped by the sensible positioning of the lever. It is also quite practical to "snatch" upward changes with the throttle foot held down. The only care necessary is not to pull the lever too far to the right when going from 2nd into 3rd, or it tends to catch on the gate; the reverse position works easily against a spring. The clutch is light and works well, but it might be a trifle more progressive. The brake pedal needs fair pressure, but gives excellent results.

The wood fascia has a centre panel carrying Lucas ammeter, ignition and lamp switch, horn button and dipper, Jaeger oil gauge reading to 100 lb.sq.in, starter pull, mixture pull, fog-lamp switch, battery charging socket, panel light switch, and screw-type, slow running adjustment. It is flanked by a dash-lamp and a 30 m.p.h. warning lamp and, on the left, is the 100 m.p.h. Jaeger speedometer with mile-o-meter and trip, and on the right the Jaeger rev-counter reading to 6,500 r.p.m. and having an inset clock. Also, on the extreme right, is a window which flashes the word "Fuel" when the tank capacity is down to about two gallons; unfortunately, it does this very vividly, right in the driver's eyes. Speedometer and rev-counter are simply but effectively



calibrated. The oil gauge is somewhat blanked by the steering wheel, but not seriously; the lamp dipper is rather too close to the wheel and could with advantage work the other way, so that it could be flicked with the left forefinger, instead of having to be fumbled for with the thumb.

The panel lighting is adequate for reading all the instruments, but too much green light leaks round them for the light to be left on while driving. The starter is up to its task and the mixture-enrichener for the twin S.U. carburettors is spring-loaded to obviate driving off in "rich" — a good point. The ignition key in the "off" position does not render the electrics dead, yet has to be "on" to work the wipers. The dynamo gives a good, controlled charge and the dual screen wipers are efficient but very noisy. Normal oil pressure is 12 lb.sq.in. and does not vary with hard driving. There are only two hexagon-motifs now visible from the seat, one in the centre of the 3-spoke steering wheel and one on the back of the license holder. The scuttle has the two familiar wind-deflecting "humps" and the screen folds flat, with a wiper box before the passenger. Entry into the M.G. is no more difficult than in any other low-built car of this type and is aided by the low running boards. Door handles and bonnet fasteners work effectively, and each door has a pocket. There is no cubby hole.

Our initial impression of the "T.C." Midget was its trim, well-balanced appearance and the high quality of the finish. The car could certainly take its place unashamedly with the "limousines and landaulettes" outside the best hotels, while there was practically no suggestion of austerity. There are carpets on the floor, and a wind excluder round the hand brake, and the finish of the car — red in our case with upholstery to match — and the equipment included, leave nothing to be desired. A most useful item of the body layout is the generous luggage space behind the seat. This is covered by a "tonneau" cover when the hood is down, or by the hood when this is erected, and will hold several suitcases, still with room to spare for coats and similar etceteras. This is a very valuable feature, and the need to carry luggage externally should never arise.

Getting away from Oxford, after inspecting that pleasingly stark 1923 o.h.v M.G. in the Nuffield Showrooms, we soon found we were cruising at 55-60 m.p.h. on the speedometer. The M.G. proved to have a very subdued exhaust note, and in towns it attracted only favourable comment and attention. We soon found ourselves keeping the engine above an indicated 2,500 r.p.m. by making full use of the gearbox, encouraged by the excellent placement of the rigid gear-lever and the ease of the change. This desire to employ the lower ratios is enhanced by a complete absence of gear noise in any ratio and only the slightest sound in the overrun. The steering we found to be really high-g geared (in quite the vintage tradition); it actually needs 1½ turns, lock to lock. The lock is moderate. As the test progressed we confirmed not only the ability to control the car by wrist movements alone, but that no return motion is felt through the wheel on any surface, and that there is admirable castor action. The wheel judders in the hands at times, but never to an abnormal degree, the scuttle, like the radiator, being commendably rigid. It is rather heavy steering through appreciable arcs, but very reasonable in normal motoring. The door cut-away tends slightly to impede the elbow when "dic-ing." This steering is in no way "spongy," and after 7,500 miles showed little lost motion.

The M.G. corners as well as its predecessors. If anything, it understeers, which is all to the good, especially as the quick castor action brings it out of corners very nicely. We could not make the car slide, even on wet roads, and it steers accurately both on the straight and when cornering. The steering remains good when reversing, which is useful in special tests, and the car certainly does not roll, even under "rally test" driving. The tyres protest rather early, but not too loudly. The suspension is pleasingly hard in quite the "old-school" manner, yet the car is not uncomfortable and can be taken over gulleys and bad surfaces without any feeling of remorse. This firmness of the suspension undoubtedly endows the "T.C." M.G. with the good roadholding aforementioned and, if it occasions a few body rattles, we feel these are entirely forgivable in view of the pleasant handling qualities achieved.

The brakes are really good. They call for fairly firm pressure on the pedal, but have a secure, hard feel, are very powerful, and progressive braking is quite easy to accomplish. There is only occasional brake noise and in the wet, if the wheels are allowed to lock, the car remains controllable.

On the first day of the test a cold wind made us resort to the excellent weather protection which we were so glad of later on. Four rigid sidescreens are stowed in a felt-lined locker at the back of the luggage compartment. They fit, two on each side, by inserting metal tongues into slots at the back and metal sockets over studs at the front, where wing nuts secure them. We soon erected the front screens and found that they excluded side draughts. When we encountered driving rain and a gale-force wind we erected the disappearing hood and the rear sidescreens, and in a matter of miles gave full marks to the weather protection of the new M.G. Midget. Hardly any rain drove in and the interior of the car was literally warmer than that of a saloon — so much so that in less severe conditions we should have removed the rear sidescreens in order to ventilate the car. The weather really was quite abnormal and the M.G. came through with flying colours, the interior almost bone dry. No one need have any qualms about using this car in winter, and this protection is rendered practical by two windows in the back of the hood, permitting of easy reversing, and by signaling flaps at the base of each sidescreen, normally secured by a press-stud tab.

As we have observed, the driving position is generally comfortable, but, unfortunately, there is nowhere to stow one's clutch foot and the accelerator is rather difficult to hold fully depressed. The fuel tank holds the useful quantity of 13½ gallons and possesses a very excellent quick-action filler cap.

Two other good points about this M.G. deserve special emphasis. One is the provision of centre-lock wire wheels, rare on modern cars. They carry 4.50 in. by 19 in. Dunlop synthetic tyres. The other is the excellent lighting. It is possible to drive at maximum speed after dark, thanks to the long-range beams from the Lucas headlamps, yet these "dim" effectively, while the small Lucas spot-lamp is one of the finest we have driven behind. The sidelamps rather reflect in the headlamps plating and so can be checked as "on" from the seat; there is a good brake lamp, but no reversing light.

We subjected the car to our usual timed tests, and here it was decidedly unlucky. Wind was gusting up to gale force across the course, which was sodden with rain — *very unfavourable conditions*. The figures we obtained are given in the accompanying table [See below – Ed.], but before you commit them to mem-

ory, some explanation is necessary. At Brooklands it was possible to work a car up to its true maximum speed. Under prevailing conditions we cannot do this, but our speed for the flying ¼-mile is a fair appreciation of what can be expected under road conditions. As usual, we did several runs in both directions of the course with the screen down, and carried a lightweight passenger and only a few gallons of petrol. The main figures were: flying ¼-mile at 63.5 m.p.h., mean speed, best run at 65.75 m.p.h. Best standing ¼-mile in 22 sec., 0-50 m.p.h. in 16.25 sec., 0-60 m.p.h. in 27.25 sec. The wet road affected the braking, which from 30 m.p.h. to a standstill occupied 41 ft.; the car slid with locked wheels and did well in the circumstances. Incidentally, before doing these tests we check the speedometer to eliminate inaccuracies; weight is ascertained on the same weigh-bridge in each case.

The engine of the "T.C." M.G. is smooth and free from flat spots, so that the speed attained before changing into a higher gear really rests with the driver. An indicated speed of 3,000 r.p.m. is very pleasant, or 4,000 r.p.m. for brisker occasions. The engine sound-ed to have reached its safe limit at an indicated 5,500 r.p.m., and the corrected road speeds were then 22½ m.p.h. in 1st gear, just over 39 m.p.h. in 2nd gear, and 56½ m.p.h. in 3rd gear. In top gear we got an indicated speed of 4,400 r.p.m. entering the measured stretch and 4,600 r.p.m. leaving it, on a run timed at 62.1 m.p.h., which shows that, given a longer run, the car would probably have improved on its maximum speed. On the road, in fact, on one occasion the speed exceeded 70 m.p.h.

It was most interesting to find that the engine did not protest in the slightest degree to "Pool" petrol. It started at once from cold, but needed some encouragement from the enricher before it would pull. It always cut clean on the switch, and in just over 400 miles no oil or water was needed. The fuel consumption, checking a tankful against the trip reading, came out at 27 m.p.g., much town work and all the timed tests included. In top gear the engine began to "take hold" above an indicated 3,000 r.p.m., and in the same ratio would run down to a few m.p.h. without transmission snatch. Beneath the bonnet the oil filler is readily accessible on the valve cover, and coil, electric fuel pump and junction box equally so on the bulkhead. The external mirror is well placed, but visibility suffers with the sidescreens up on a wet night. The starting handle is clamped to the front of the luggage shelf and the tools are in a locker beside the battery box on the bulkhead. The engine is finished in light grey paint and the rev-counter is driven from the belt-driven dynamo. The wheel-base is 7 ft. 10 in., the track 3 ft. 9 in., and those with garaging problems may like to know that the overall dimensions are 11 ft. 6 in. by 4 ft. 8 in.

To sum up, the "T.C." M.G. Midget is a good-looking, attractive car. It corners very well indeed, and its excellent gear-change and good brakes, together with "vintage-like" roadholding and suspension, enable it to live up to its slogan of "Safety Fast." Its other characteristics, if less outstanding, are equally satisfactory, and its economical speed, willing acceleration and very practical and complete equipment, combine to render this car a thoroughly useable 2-seater. Full details from the M.G. Car Company, Ltd., Abingdon-on-Thames, Berkshire. The price, with purchase tax, is £527 16s. 8d. [\*] — W. B.

[\* 2008 value: £15,400 or \$22,513.26 — Ed.]

**Engine:** 4 cylinders, 66.5 by 90 mm.  
(1,250 c.c.), 11 R.A.C. h.p.

**Gear Ratios:** 1st, 17.32 to 1; 2nd,  
10.0 to 1, 3rd, 6.92 to 1; top, 5.125 to 1.

**Tyres:** 4.50 in. by 19 in. Dunlop synthetic.

**Weight** (in road trim with approx. 3 gall.  
of fuel, but less occupants): 16½ cwt.

**Steering Ratio:** 1 5/8<sup>th</sup> turns, lock to lock.

**Fuel Capacity:** 13½ gall. (2-3 in reserve).

#### PERFORMANCE DATA

##### Acceleration:

0-50 m.p.h., 16.25 sec.\*

0-60 m.p.h., 27.25 sec.\*

s.s. ¼ mile: 23.45 sec.

(mean), 22.0 sec. (best run)

\*(mean of two-way runs)

##### Speed:

f.s. ¼ mile : 63.50 m.p.h. (mean),

67.75 m.p.h. (best run)

Maximum in indirect gears (corrected  
for speedometer error):

1st: 22.6 m.p.h. at 5,500 r.p.m.

2nd: 39.2 m.p.h. "

3rd: 56.6 r.p.m. "

**Fuel Consumption:** Approx. 27 m.p.g. □

### MG QUIZ No. 1

Pictured are TCs on the Abingdon assembly line, but what are those hard-topped vehicles lined up over on the left? □



No. 1339  
 TC M.G.  
 MIDGET  
 TWO-SEATER

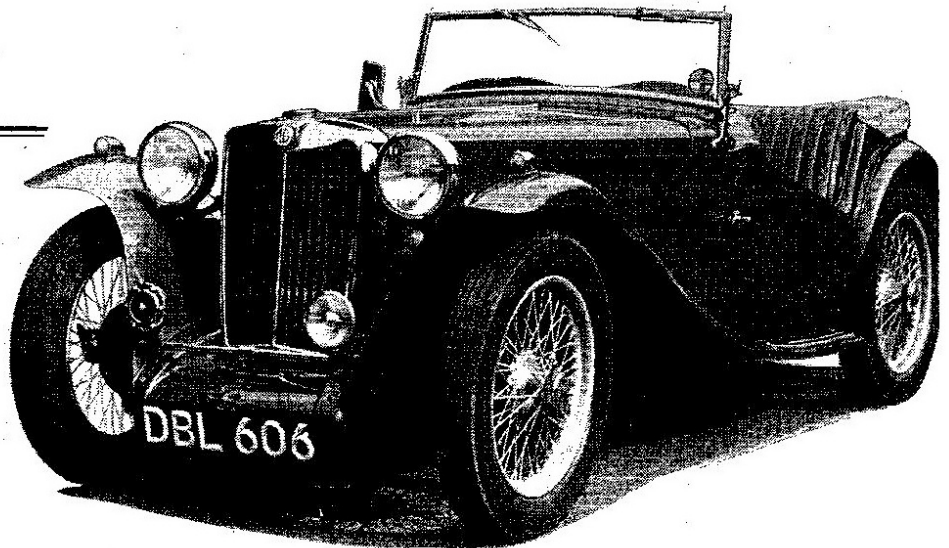

# *The Autocar* ROAD TESTS

## DATA FOR THE DRIVER

TC M.G. MIDGET.

PRICE, with open two-seater body, £412 10s, plus £115 6s 8d purchase tax. Total, £527 16s 8d.

RATING: 10.97 h.p., 4 cylinders, overhead valves, 66.5 x 90 mm, 1,250 c.c. TAX (1947), £13.

BRAKE HORSE-POWER: 54.4 at 5,200 r.p.m. COMPRESSION RATIO: 7.25 to 1. WEIGHT, without passengers: 16 cwt 19 lb. LB. PER C.C.: 1.45.

TYRE SIZE: 4.50 x 19.0in on knock-off wire wheels.

LIGHTING SET: 12-volt. Automatic voltage control.

TANK CAPACITY: 13½ gallons: approx. fuel consumption range, 28-34 m.p.g.

TURNING CIRCLE: 37ft (L. and R.). MINIMUM GROUND CLEARANCE: 6in.

MAIN DIMENSIONS: Wheelbase, 7ft 10in. Track, 3ft 9in (front and rear). Overall length, 11ft 7½in; width, 4ft 8in; height, 4ft 5in.

### ACCELERATION

Overall gear ratios	From steady m.p.h. of		
	10 to 30	20 to 40	30 to 50
5.125 to 1	12.1 sec.	13.5 sec.	14.9 sec.
6.93 to 1	8.9 sec.	9.5 sec.	10.3 sec.
10.00 to 1	6.2 sec.	6.6 sec.	---
17.32 to 1	---	---	---
From rest through gears to:--			
30 m.p.h.	---	---	5.7 sec.
50 m.p.h.	---	---	14.7 sec.
60 m.p.h.	---	---	22.7 sec.

Steering wheel movement from lock to lock: 1½ turns.

Speedometer correction by Electrical Speedometer: 10 (car speedometer) = 7; 20 = 22; 30 = 29; 40 = 41; 50 = 50; 60 = 59.5; 70 = 70.

Speeds attainable on indirect gears (by Electrical Speedometer) (normal and max.):  
 1st .. .. . 15-25  
 2nd .. .. . 32-40  
 3rd .. .. . 52-61

WEATHER: Dry, warm; wind light.

Acceleration figures are the means of several runs in opposite directions.

Current model described in "The Autocar" of October 12, 1945.

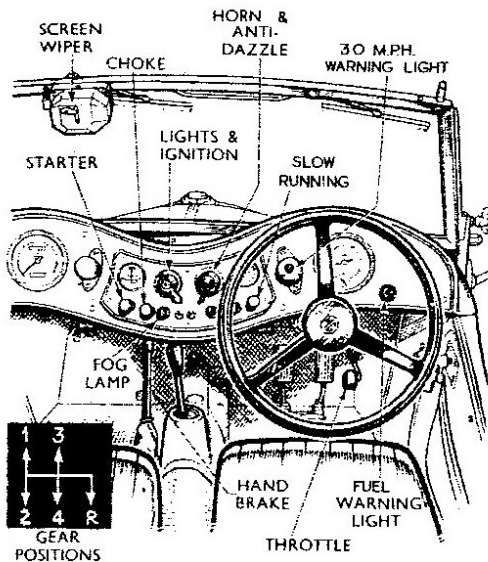

In a motoring world in which there is so much talk as there is today of rationalization, and in which cars tend more and more to resemble one another in appearance as well as performance for a given size, the M.G. Midget two-seater stands unique. Yet an interesting point, as shown by recent public utterances on export subjects as well as other sources of information, is that this car does not appeal only to the trials-minded and youthful fraternity of motorists in this country. On the contrary, it is gaining more and more of a following in other countries, including the U.S.A., and has reached a position where it can be regarded as one of our more exportable cars in terms of proportion of total output of the model.

Today it is certainly a class alone among cars made anywhere in the world as a sporting type retaining the conventional outward appearance of the "real" car dear to the hearts of enthusiasts in years gone by — that is, by displaying its radiator, or at all events a normal grille, and lamps, and in not having gone "all streamlined." It is a model, too, which more than most cars has evolved through the years, with its beginnings in that much smaller Midget of 17 years or so ago that instantly registered a success. No car has done so much to maintain open-air motoring and to support the demand that exists all over the world for sports car performance and characteristics in a car of not exorbitant first cost and at moderate running costs.

It offers a great deal in sheer performance, yet is not just a sports car with an appeal limited to special occasions; instead it is in every way a perfectly practical car for all occasions where two seats are sufficient and the fresh air style of progress is preferred. Actually, the all-weather equipment is good, the hood being easily erected and the side screens likewise, and they turn this car into a very reasonable imitation of a permanently closed car for bad weather use.

The Midget is in no way more difficult to drive than the ordinary family saloon, but given the type of driver who usually falls for such a machine — not necessarily a youngster — and who likes to use the gear box, the performance becomes quite vivid. That is not to suggest the gear box has to be used in the manner of a pump handle whether the driver chooses or not; the 11 h.p.-rated engine that the TC Midget possesses has quite a range of flexibility in top gear, and the car is tractable in traffic. On the other hand, with an engine that will rev very freely without complaint much more can be made of the performance, of course, by using indirects that offer maxima as high as 60 m.p.h. in third and 40 in second.

Owing to the handy size of this car, its ability to pass safely where a bigger car would be held back, and the way in which it regains its cruising rate after it has been held back by other traffic, the Midget is almost as fast a car, over British roads, as can be found today. One feels, too, from its ability to take hard treatment and to hold speeds between 60 and 70 m.p.h., apparently for as long as roads in this country permit such motoring, that stretches of motor road offering far more opportunity of sustained speed than ever is found in this island would not “melt” a Midget engine.

The hardness of the car, the way in which it helps the driver in its manner of cornering, its “quick” steering, are big factors in giving it unusual average speed capabilities without an extremely high maximum speed being attained. The present car has been handled over a considerable distance in conditions which provided crowded roads, and also over routes on which traffic had been thinned by seasonal and petrol considerations. In both circumstances, the average speeds were exceptional, a 40-miles-in-the-hour showing seeming always to be within its reach on a journey of any length, while, when roads are clear, figures such as 44 and 46 m.p.h. averages have been obtained. When the car was being timed by *The Autocar's* electrical speedometer showed only 73, an unusual state of affairs. In other more helpful road conditions subsequently the car's speedometer was seen at the 75 mark.

### Sense of Accurate Control

Always one has the feeling of being able to make a fast run easily in the Midget, for it responds so readily to all the controls and is so quick — *eager*, it seems, to get moving. The biggest factor in this and other directions, apart from the actual performance available, is the complete sense of command which the driver feels he has over the car at all times, including the major features of brakes, steering and road holding on corners. The Lockheed brakes deserve special mention, for they deal most effectively with high-speed braking, and also are powerfully smooth in low speed applications.

Merits and demerits of normal versus independent suspension can be argued, in the main to the latter's marked advantage, but there is no doubt of one fact in this connection. The nor-

mally sprung car, rather hard sprung, as in this instance, does let the driver gauge within close limits the speeds at which he can corner safely fast. After a little experience of it one finds oneself holding quite high speeds round bends in the Midget, and the car steering to a close course only a foot or two out from the near-side verge. Such a half-elliptic suspension has, of course, the counter-balancing feature that it is on the harsh side over poor surfaces, but on the Midget this tendency is by no means excessive.

It is a trim and appealing little car in its general arrangement and very practically laid out, besides offering a considerably higher accessibility factor than is usual today. One quickly comes to feel an affection for its efficiency and willingness, and in all respects, including performance, it is “man-size,” with no suggestion of the tiny car about it.

### Driving Position and Controls

Doubly important in a car of this type is the driving position. The Midget is provided with an adjustment for the seat back rest, which is in one piece, although there are two separate cushions, whilst also the spring-spoked steering wheel is telescopically adjustable and can be paced ideally for full power of control. A feature much appreciated or disliked, according to the point of view, is the fly-off type of hand brake lever — in *The Autocar's* view a form of control to be highly commended for its certainty and positiveness of operation. A more comfortable position for the left foot off the clutch pedal would be welcomed.

The gear change has synchromesh in second, third and top, and with a short vertical lever, which is well placed, this works very well for really quick upward and downward changes when the utmost is being made of the performance potential. The instruments include a rev counter, and the engine can be taken round to 5,500 r.p.m. with celerity, and it will readily go beyond that figure.

One does not think of this car in the usual way in terms of top-gear climbing ability. Actually, however, the capabilities in this direction are good, for the power-to-weight ratio is favourable, but it is a delight to drop to third and fly over the gradients that bring the speed down at all appreciably in top. As to steeper gradients, second gear lets the car tear up a hill of 1 in 6½ caliber.

The head lamps are good for fast night driving. Starting from cold is immediate, and not much use of the mixture control for the twin S.U. carburetors is needed before the engine will pull properly. An excellent point, of value here, but still more so in territories where filling facilities are widely spaced, is the big petrol tank, giving a range of action of approximately 400 miles.

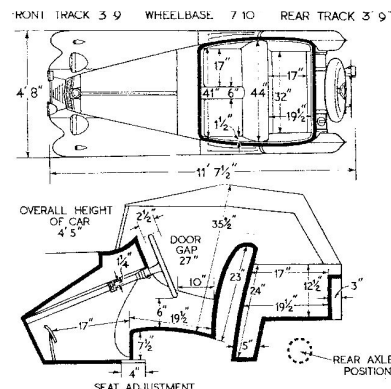

## TC Production

<u>Year</u>	<u>Chassis Nos.</u>	<u>Quantity</u>
1945	TC0251 - TC0351	81
1946	TC0352 - TC2051	1,675
1947	TC2052 - TC4411	2,346
1948	TC4412 - TC7502	3,085
1949	TC7503 - TC10251	2,813
<b>TOTAL:</b>		<b>10,000</b>

**Exported to USA: 2,001\***

**\*Official figure (privately shipped vehicles not counted)**

---

### A Final Word

From The Editor

We recall reading somewhere that a well-known British automotive writer, asked a few decades ago what he thought of the MGTC, quipped that it looked like a coffin riding on four harps.

Everyone is entitled to one's own opinion, especially where aesthetics are concerned. However, we would have thought he might usefully have observed that the TC was (a) the car that put the phrase "sports car" into the Oxford English Dictionary (viz., "an open, low-built, fast motor car"), or (b) that it helped resurrect Great Britain's automobile industry and export earnings in the aftermath of World War II, or (c) that years later, many of its 10,000 units were still being restored, pampered, shown and raced by enthusiasts in countries around the world, or (d) that its legendary success could not possibly have been predicted in 1945 by anyone who knew anything about its very modest size, power and layout.

We could go in this vein. Suffice it to say that we True-Believers can attest to the sheer fun there is to be had in driving our T-Series MGs, and this is particularly true with respect to the TC. Its tough XPAG engine, properly maintained, can stand a fantastic amount of abuse, as the racers among us will confirm. Its rock-solid rigidity was phenomenal in relation to its size and output, and the car's superb handling provided excellent training for novices who went on to glorious careers in big-time F1 and GT racing — America's Phil Hill being a prime example.

So let no one speak disparagingly of our venerable little friend, the TC, with its high clamshell fenders, vintage radiator shell, handsome 17-inch steering wheel, 19-inch wire wheels (same size used by Ford's Model A, in case you didn't know), and incomparably steady and predictable handling. Only one drawback will we admit to: on very bumpy surfaces it rides with all the subtle grace of a pneumatic hammer. As if to compensate, it performs magnificently, like its T-Series brothers, on twist-

ing asphalt, gravel and dirt roads. In its hey-day, no piece of Detroit iron could hold a candle to the road manners exhibited by the TC.

Truth being told, the TC was not without faults, but we Americans loved it in spite of them, maybe even because of them.

As Road & Track founder John Bond wrote in 1956: "For a comfort-loving public [it] was wretchedly impractical; your spine was jolted, your knees bumped, you were hot in the sun and wet in the rain, you had no luggage space and only 54 hp — but for the first time in many a year you were driving a car. A person felt it was part of him, as quick and responsive to commands as a well trained mare, and for many a U.S. driver this was something new and wonderful." And, of course, it looked terrific: classically "correct," rakish yet elegant — English decorum with wire wheels and cutaway doors.

We therefore may be forgiven feeling tingles of expectation when we climb into a TC, look through its strip of a windscreen and past the long, forward-looking hood, high fenders and big headlights, start up the engine, thrill to the growl from the muffler, snap a ¾-tonneau cover around us, and glance at that great, impatiently ticking tachometer. Might we perhaps be Tazio Nuvolari, straining for the starting flag at Brescia? . . .

Sure feels like it! ☐

---

### A Suggestion and an Invitation

Would you like to have the option of being part of an interesting automobile event on just about any weekend?

As our sister MG car club's organ, *The Spark*, reported recently, this event can be found at the "Cars and Coffee" get-together that takes place every Saturday morning, 7:00-9:00 am, at Great Falls, VA. An Alfisti friend of ours checked it out some time ago and reports he had a fine time, with the organizers having enthusiastically encouraged all his Alfisti buddies to participate.

The concept is simple: create an informal meet-up with no fees, no program, and no requirements other than bringing a classic or sports car (or come in the family car and just be a spectator). Each Saturday will have a different display of interesting cars depending on who (and what) shows up. What could be a better start to a car enthusiasts's weekend than a chance to display one's car, view a diverse sampling of other makes and models, and meet other gear-heads, polishers, racers, collectors, tourers and just plain car nuts?

Great Falls is 6 miles from I-495, off at DC Beltway Exit 44 and on VA Route 193 West. You'll find the event in a convenient parking lot adjacent to Katie's Coffee House in the village center just off Georgetown Pike (Rte 193). Katie's is located behind B&T Bank (which is right on Rte 193) and next to The Old Brogue Restaurant.

The event takes place every Saturday from April 1 until the last Saturday in October, weather permitting. It would be swell to have a nice showing of T-Series MGs, so we hope to run into some other Chapter members there on future Saturdays, as better weather sets in. ☐

## MG T-Series Web Sites

Brainchild of Milton Babirak

Thanks to Milton, we have the impression, gained in the course of his conversations with many T-Series fans, that some of us seem unfamiliar with what the Internet can offer in terms of info on the histories and activities of other MG clubs, as well as technical data and advice, sources of spare parts, photograph collections, and background information on virtually every aspect of the care and feeding of T-Series cars. So we have undertaken to compile and maintain a list of web page “addresses” (URLs) aimed at helping Members gain access to these broader sources of information about our Little British Cars. Although the number of web sites appears virtually endless, we’ll begin with an annotated list of a dozen favorite “links” (mostly British) which Members may find interesting and useful. We expect to add to this list from time to time, and we’d welcome tips from Members who themselves might wish to suggest additional links.

[www.nemgtr.org/](http://www.nemgtr.org/) Puts you in touch with the New England T-Series Register, whose scope encompasses North America and includes our own and 23 other regional Chapters, plus other affiliates. Click on this link to keep abreast of NEMGTR activities and peruse its bi-monthly magazine, The Sacred Octagon.

[www.british-cars.co.uk](http://www.british-cars.co.uk) We find this web site especially useful because it offers (a) a forum in which one can pose technical questions and receive answers in real time, and — what is perhaps even more useful — (b) an archive that contains searchable compilations of Qs and As (“threads”) stored over the past five years or more. Forum participants appear to be both knowledgeable and helpful, while the archive can be even more informative since it covers so many questions that have already been asked and answered. Members may wish to test this feature by submitting a question or two of their own. We think the answers won’t disappoint them.

[www.mgcars.org.uk/](http://www.mgcars.org.uk/) Operated by the MG Enthusiasts’ Club (UK), this web site contains an excellent history of MGs in general and T-Series cars in particular. Restorers will appreciate the “Gallery” section’s many photos, as well the “Details” section’s thorough coverage of points regarding originality, finishes, fasteners, and tools.

[www.mgcc.co.uk/](http://www.mgcc.co.uk/) Will take you to the primary web site of the MG Car Club Ltd. (UK), formed under factory auspices in 1929, but an independent entity since 1969. Its offices (since 1990) are in the renovated “Kimber House,” adjacent to the former site of the MG factory in Abingdon that closed forever in 1980. Enthusiasts are encouraged to visit. The site lists participating “Centres” in Great Britain and around the world (one of them being our pals at The MGCar Club, Washington, DC Centre). Its activities include *Safety Fast* magazine, ads of cars for sale, a buyers’ guide, support for racing events, car shows, an online shop, and active efforts to preserve the grand history of the marque. Lots of MG history and photos are to be found on tap. Speaking of tap, Abingdon (pop. 36,626) counts 23 pubs within the town limits.

[www.mgabingdon.org.uk/](http://www.mgabingdon.org.uk/) This is the site of the MC Car Club (UK)’s “Abingdon Works Centre,” formed in 1982 and represented by a small museum in Abingdon’s former (17th Century) County Hall. Its activities include hosting enthusiasts’ meetings, organizing frequent rallies and “road-runs,” conducting tours of what remains of the former factory premises, and welcoming visiting MG fans from around the world. Ads for buying/selling cars are kept on file, along with an online regalia shop.

[www.tregister.org/](http://www.tregister.org/) Has a feature labelled “Production Records” which, if you enter your car’s chassis number, will tell you the exact date it emerged from the factory at Abingdon. Other interesting features include lists of all MG-related web sites worldwide.

[www.classiccarsforsale.co.uk](http://www.classiccarsforsale.co.uk) This well-run site lists classic cars for sale in the UK, where the selections are far greater (but the prices steeper) than in the U.S. It is updated almost daily and can automatically alert customers when new postings are made for a particular type of car.

[www.britishcarlinks.com](http://www.britishcarlinks.com) Displays a list of links to MG-related web sites that appears to be almost endless. It can also help to identify “mystery” vehicles, usually British models that have been seriously modified.

[www.mgauctionwatch.com/](http://www.mgauctionwatch.com/) Very useful in finding T-Series parts. Milton, our Membership Chairman, describes his personal experience with this feature as “very good.” Not useful for buying/selling cars, however.

[www.homepages.donobi.net/sufuelpumps/](http://www.homepages.donobi.net/sufuelpumps/) If you scroll down on the site and select “sufuelpumps,” you’ll find everything you ever wanted to know about SU fuel pumps.

[www.baconsdozen.co.uk/tools/whitworth.htm](http://www.baconsdozen.co.uk/tools/whitworth.htm) We think this site is very useful. Maybe we ought to use its contents to sharpshoot John Twist and try to stump him.

[www.conceptcarz.com](http://www.conceptcarz.com) Bills itself as a “premier website for auto enthusiasts seeking vehicle info from concept to production and from vintage to modern [and] offers in-depth articles, news, reviews, high-quality photography and desktop wallpaper.” In the latter categories, one should type “MG” in the search box in order to view the extensive collection of photographs, some going back many decades. □

**A Word to the Wise**  
**for**  
**Fairfax County Taxpayers**

Brought to our attention on 08/02/10 by John Hambleton, who wrote:

A month or so ago, I received Fairfax County's Personal Property tax bill in the mail. Included in this bill was a \$33.00 registration fee for my MG TD. If you click on the link below, once it is open, go to "exemptions." You will see that your antique car registered with the state of Virginia is exempt from this fee.

The county neglects to tell you this, presumably in hopes you will just send in the fee without questioning it.

I trust this alert will save you some money.

Here is the appropriate citation for the exemption:

**Section 4-17.2-2. Exceptions; local vehicle registration license fee. . . .**

2. The local vehicle registration license fee shall not be applicable to the following classes of vehicle: . . .

(f) Upon proof of State qualification and payment of the appropriate personal property tax, the following eligible applicants are entitled to exemption from the local vehicle registration license fee on one (1) and one (1) only vehicle:

. . . (5) Any owner of antique motor vehicles as defined and licensed under Virginia Code § 46.2-730.

And here's the link to the full text of the passage the above excerpts were taken from. Click on it, go to the paragraph labeled Fee Exceptions, Section 4-17.2-1, and click on [Exemptions](#).

[http://www.fairfaxcounty.gov/dta/cartax\\_veh\\_reg\\_fee.htm](http://www.fairfaxcounty.gov/dta/cartax_veh_reg_fee.htm)

**Car Notes from All Over**

Mike Hughes, ever on the lookout for the esoteric, sends us this:

**How long have you owned a car?**

Mr. Allen Swift ( Springfield, MA)  
received this 1928 Rolls-Royce Picadilly P1 Roadster from his father, brand new — as a graduation gift in 1928. He drove it until his death last year . . . at the age of 102!



He was the oldest living owner of a car from new. He donated it to a Springfield museum after his It has 170,000 miles on it, still runs like a Swiss watch, dead silent at any speed, and is in perfect cosmetic condition. (82 years)  
That's approximately 2000 miles per year.

**What a car; what a guy!!!**

**Advertisement**

**Vintage Restorations Limited**

*English Auto Restoration & Service*

Ground-Up Or Partial Restorations  
Body Panel Repair Welding & Fabrication  
Complete Body Refinishing & Wrinkle Finish Painting  
Engine & Gearbox Rebuilding  
Chrome & Nickel Plating  
Routine Maintenance & 150 Point Evaluation

*Owned & Operated By Classic Car Enthusiasts.  
Specializing In MG, Triumph, Land Rover & Jaguar.*

**Authorized MOSS Motors Parts Distributor**

52 North Main Street, PO Box 573  
Union Bridge, Maryland 21791

[www.vintagerestorationsltd.com](http://www.vintagerestorationsltd.com)

**410-775-0500**



MEMBER



This how Stephen survived the Blizzard of 2010

